

INTERFACING
 CES WIRELESS
 TRK-240-A001 MOBILE DATA TERMINAL
 MDC-210-A001 Base Modem
 MDC-150-A001 Base Modem
 TO
 SEA MODEL ESP604 - DATA RADIO



This application note provides the basic cable wiring information for connecting a SEA *ESP604* mobile data radio to either the CES Wireless Model *MDC-210 A001* or the CES Model *MDC-150 A001* base modem controller or the CES Wireless *TRK-240-A001* Mobile Message Display Terminal (MDT). This note provides the necessary wiring and setup information for a basic data system. The information in this application note is believed to be correct at the time of issuance but is provided strictly as a courtesy to SEA customers without warranty.

1. Minimum system requirements:

•

- 1 - CES Wireless Model *TRK-240 A001* Message Display Terminal configured for use on SEA Data Radio *ESP-604*. *
- 1 - CES Wireless Model *MDC-210 A001* or *MDC-150 A001* Base Modem Controller with related application software.
- 2 - SEA *ESP604* Data Radios with AFSK data option board (ASY-0600-11) installed.
- 2 - Radio to MDT interface cables (supplied by CES part number TRK-240/01). Refer to section 2 for details.
- 1 - PC to *MDC-210/MDC-150* interface cable. Use standard RS-232 DB-9 (female) to DB-25 (male) interface cable.

2. SEA Radio to CES *TRK-240 A001* / *MDC-210 A001* / Model *MDC-150 A001*

**ESP604
DB-9 Male**

**CES Device
DB-25 Male**

<u>PIN #</u>	<u>Description</u>	<u>PIN #</u>	<u>Description</u>
--------------	--------------------	--------------	--------------------

1	---	DCD	---	Not Used	---	
2	---	RD	---	3	---	Receive Audio (YEL)
3	---	TD	---	4	---	Transmit Audio (ORG)
4	---	CLK	---	Not Used	---	
5	---	GND	---	2	---	Ground (BLK)
6	---	DSR	---	Not Used	---	
7	---	PTT	---	11	---	Press to Talk (L. BRN)
8	---	CTS	---	13	---	Busy/Trunk (GRY)
9	---	+13VSW	---	1	---	Power Input (RED)

3. ESP604 Programming:

- Program the desired modes in the *ESP604* to match the REPEATER SYSTEM(S) which will be used or CHANNEL(S) for talk-around use if no repeater is being used. Refer to the *ESP604* programming manual for instructions on programming the radio for DATA operation.

A regular mode (not available on test modes) is programmed for 1200 bps data operation as follows:

Required Configuration Programming:

Data Option Type: MSK - ([AFSK data option board must be installed](#))

Required Mode Programming:

Type: Trunked or Conventional
Area: Site Area bit
Home: Desired home channel of site
Busy Channel Y
Lockout:
Repeater Channel: Channel number in Home position
Data ID: RX and TX ID

When the radio is on a mode programmed for Voice & Data, the Local Mic may key for voice operation and the MDT may key for data operation. When the radio is on a mode programmed for Data Only, only the MDT may key it. Please note if selecting Voice & Data operation, a TX and an RX ID (that do not match the Data ID) are also required for the mode programming.

4. SEA Repeater system programming:

- Optional: Talk-around users may bypass this section.

Program repeater(s) according to the *ESP1000/ESP1100* Instruction manual with the correct Channel Number, Area Bit and Home Channel. Test the repeaters with a couple of mobiles in **VOICE** mode to insure system is functioning properly before using the **DATA** mode on the mobiles.

5. Base Station Configuration:

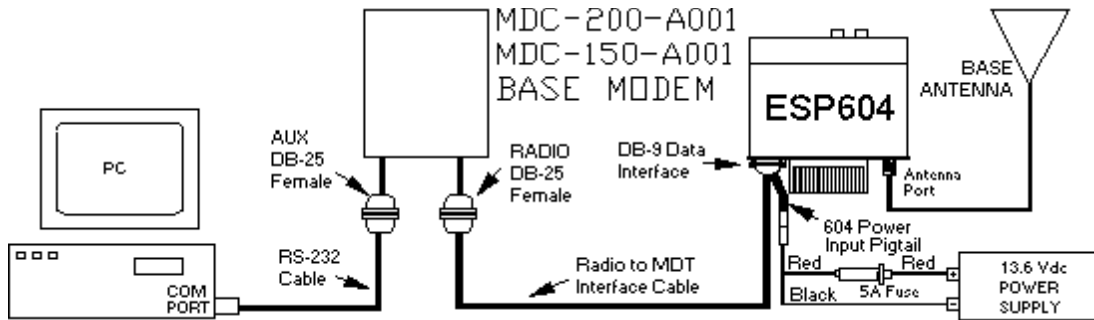

6. Mobile Station Configuration:

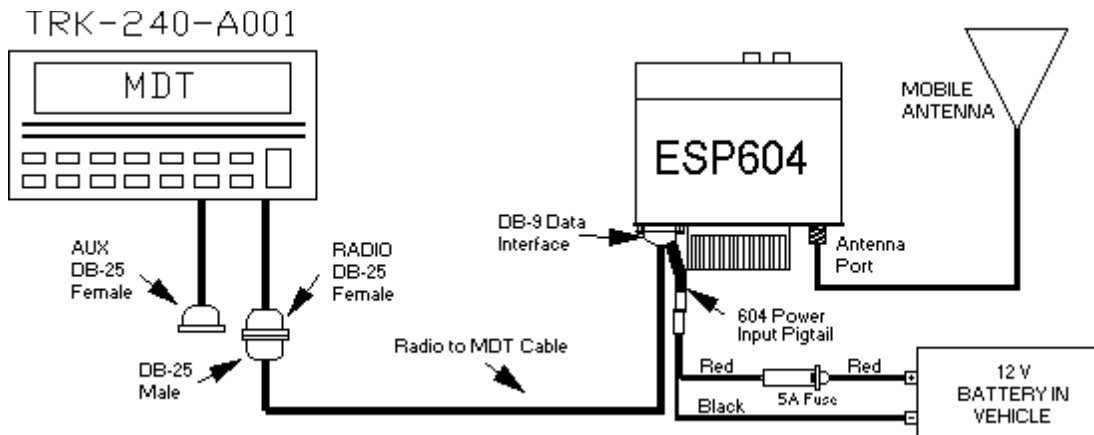

7. CES Device - Set-Up Parameters for Conventional Data Operation:

- **TX Level** = 1Vp-p (Adjust R15 on Modem board while monitoring level with an oscilloscope on pin 3 of DB-9 connector into radio.)

RX Level = 800mVp-p (Adjust R10 on Modem board while monitoring level with an oscilloscope on TP1 on same board.)

Baud rate = 1200 Radio Type = NO BUSY

- Lead In Delay = 60 (600mS) default
- Busy/Request Check = 10 (100mS)
- Request Window = 200 (2000mS)
- Grant Check = 20 (200mS)
- Grant Window = 200 (2000mS)
- Ack Response Time = 200 (2000mS)
- Ack Wait Time = 500 (5000mS)
- Retry Window = 500 (5000mS)

8. CES Device - Set-Up Parameters for Trunked Data Operation:

- **TX Level** = 1Vp-p (Adjust R15 on Modem board while monitoring level with an oscilloscope on pin 3 of DB-9 connector into radio.)

RX Level = 800mVp-p (Adjust R10 on Modem board while monitoring level with an oscilloscope on TP1 on same board.)

Baud rate = 1200 Radio Type = LTR

- Lead In Delay = 10 (100mS) default
- Busy/Request Check = 50 (500mS)
- Request Window = 200 (2000mS)
- Grant Check = 20 (200mS)
- Grant Window = 200 (2000mS)
- Ack Response Time = 25 (250mS)
- Ack Wait Time = 500 (5000mS)
- Retry Window = 500 (5000mS)