

# INTERFACING KING KDT5000 MOBILE DATA TERMINAL TO ESP604 DATA RADIO



This application note provides the basic cable wiring information for connecting a SEA ESP604 mobile radio to either the King (MDT) base terminal or King mobile terminal. Additionally, a procedure is provided for minimally configuring the PC, base and mobile terminals so that the system can be tested using the King demo application program WinDispatch. The program WinHost is the King communications port driver program which runs in the background and passes commands from WinDispatch to the base radio. The information in this application note is believed to be correct at the time of issuance but is provided strictly as a courtesy to SEA customers without warranty.

## 1. Minimum system requirements:

- 2 - King MDTs Model #5000 (One will be programmed for base use and the other for a mobile.) **Additional setup is required for correct operation - refer to Appendix A for details.**
- 2 SEA ESP604 Data Radios with AFSK data option board (ASY-0600-11) installed.
- 2 - Radio to MDT interface cables (not supplied). Refer to section 2 for details.
- 1 - PC to MDT interface cable (not supplied). Refer to section 3 for details.
- 1 - PC with 32-bit Windows 95/98 or NT 4.0 operating system.
- 1 - Software: King Communications CD containing Handyman program Ver 3.0.94 or later and Winhost 5.03.04 or later.

**WARNING!!!:** Do not plug the MDT 5000 DB-9 male connector directly into the female data connector on the ESP604 as may cause damage to the radio and MDT. Use only the wiring shown below for making proper wire harness cables.

## 2. PC to MDT Cable (Null-Modem Cable):

**P.C. Side**  
**DB-9 Female**

**MDT Side**  
**DB-9 Female**

**Description**

2	-----	3	-----	TD
3	-----	2	-----	RD
6	-----	4	-----	DTR
4	-----	6	-----	CTS
7	-----	8	-----	(Not Used)
8	-----	7	-----	(Not Used)
5	-----	5	-----	GND
		9	-----	+13V out

### 3. Radio to MDT Cable:

<u>ESP604</u>		<u>Description</u>	<u>King MDT</u>		<u>Description</u>
<u>DB-9 Male</u>			<u>DB-9 Male</u>		
1	----	DCD	-----	Not Used	
2	----	RD	-----	4	---- Receive Audio (1200 Baud MSK)
3	----	TD	-----	8	---- Transmit Audio (1200 Baud MSK)
4	----	CLK	-----	Not Used	
5	----	GND	-----	1	---- Ground
6	----	DSR	-----	7	---- Carrier Detect (COR)
7	----	PTT	-----	3	---- Press to Talk
8	----	CTS	-----	6	---- Clear to Send (CTS)
9	----	+13VSW	-----	5	---- Power Input

**NOTE:** Be sure to mark each end of the Radio to MDT cable as it is a DB-9 male on both ends. If the ends are reversed they will not damage the MDT or ESP604 but will prevent your system from operating.

### 4. ESP604 Programming:

- Program the desired modes in the ESP604 to match the REPEATER SYSTEM(S) which will be used or CHANNEL(S) for talkaround use if no repeater is being used. Refer to the ESP604 programming manual for instructions on programming the radio for DATA operation.

A regular mode (not available on test modes) is programmed for 1200 bps data operation as follows:

○

#### **Required Configuration Programming:**

Data Option Type:

MSK - AFSK data option board (ASY-0600-11)

must be installed

**Required Mode Programming:**

Type:	Trunked or Conventional
Area:	Site Area bit
Home:	Desired home channel of site
Busy Channel Lockout:	Y
Repeater Channel:	Channel number in Home position
Data ID:	RX and TX ID

When the radio is on a mode programmed for Voice & Data, the Local Mic may key for voice operation and the MDT may key for data operation. When the radio is on a mode programmed for Data Only, only the MDT may key it. Please note if selecting Voice & Data operation, a TX and an RX ID (that do not match the Data ID) are also required for the mode programming.

**5. SEA Repeater System Programming:**

- Optional: Talkaround users may bypass this section.

Program repeater(s) according to the ESP1000/ESP1100 Instruction manual with the correct Channel Number, Area Bit and Home Channel. Test the repeaters with a couple of mobiles in voice mode to insure system is functioning properly before using the DATA mode on the mobiles.

**6. Mobile Station Configuration:**

- A. Select a 2 or 3 digit **ID** number to program the mobile data terminals. Refer to the **DOCUMENT** section of the **KING CD** for programming the MDT with the configuration program - **EXC**.  
NOTE: Use Base Station System Configuration (below) to make changes in the MDTs.
- B. **System Configuration:**

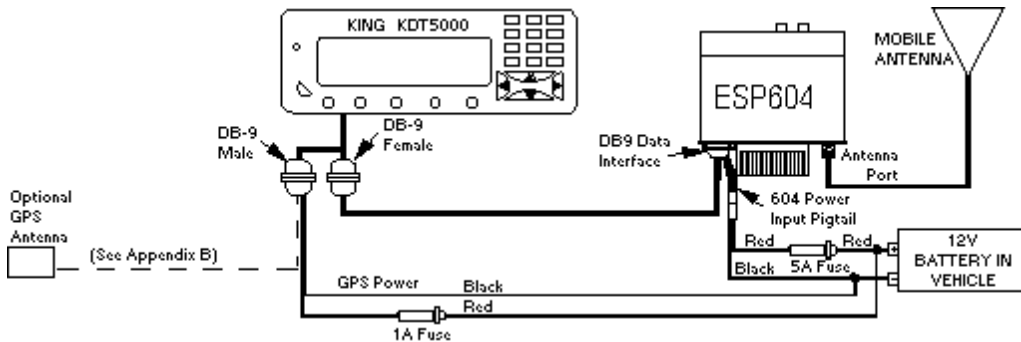

**7. Base Station Configuration:**

- A. The KING MDT **ID #** must be set at **2024** for base operation. Refer to the **DOCUMENT** section of the **KING CD** for programming the MDT with the configuration program - **EXC**.
- B. **System Configuration:**

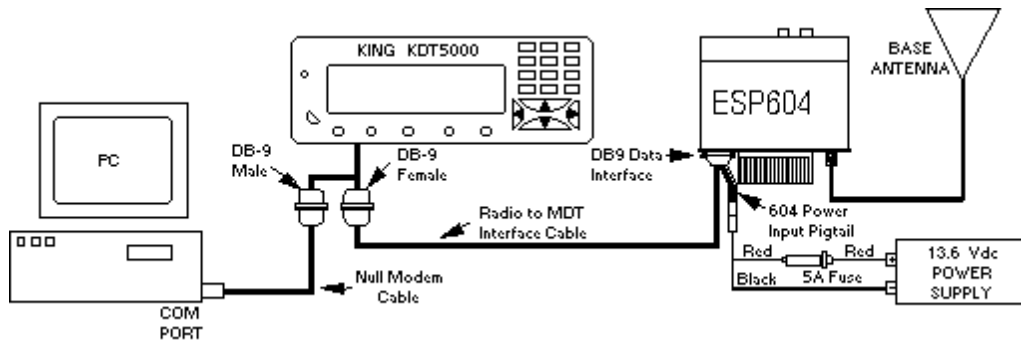

## 8. Minimum required Base Station Configuration Procedure:

- A. Place the **King Communications CD** into the personal computer CD-ROM drive bay.
- B. Select **RUN** program from Windows Taskbar. Select the CD ROM Drive and type: **SETUP** , then press return. NOTE: Setup is in the root directory of the KING CD.
- C. Select **YES** to install Handyman. Follow the instructions for a **TYPICAL INSTALL**
- D. After completing the installation, go to **START** menu / **PROGRAMS** and then the **KING** directory. Select **Winhost 1** or **Winhost 2** depending on which COM port you are using.
- E. Click on **Handy** when **Winhost** is activated. When the Handyman window comes up, select **HELP / Handyman/Getting started**.
- F. Review this section and following the instructions given. Review other sections of help to get a full understanding of how the program operates.
- G. With the opening main menu, select **FILE**, then select **SETTINGS**, and go to **VEHICLE**.
- H. Add the vehicle **ID #** and **Driver Name** to match the programming of the mobile MDT. Save created data, exit and return to the **MAIN MENU**.
- I. Select **Booking**. Follow instructions in the HELP file to send jobs to a mobile unit with a matching ID.
- J. For **GPS** operation **SEE APPENDIX B** for setup instructions.

## APPENDIX A

### King Mobile Data Terminal Configuration Setup

Using the **EXC** utility program that is included in the **King Communications CD** installation, you will have the ability to program specific parameters of the **MDT** operation. **EXC** will be found under the **King** directory in your task manager. The procedure described below must be performed on both base and the mobile **MDT** for use with the ESP604.

- I. Connect a power supply of **13.6VDC** to the **MDT** using either method listed below.
- II.
  - A. By using the cables specified in **SECTION 3**, you can connect an **ESP604** to power and using the interface cable between the radio and the **MDT** to supply power.

- B. By using the female **DB9** connector of the **MDT** (No radio is needed for this method). The (+) lead going to **PIN 5** and the (-) to **PIN 1**.
- III. Connect the computer to the **MDT\*** as shown in the Base Station Configuration (See Section #7).
- IV.
  - A. Make note of which serial port you are using as the EXC utility program will need to be launched using the correct port.

With power applied to the MDT and computer's serial port attached, execute the EXC utility that corresponds to the port you are using (COM 1 or 2). If the system is working correctly, it will respond with a red **UNK**. Press the "Enter" button on the keyboard several times. You should receive the same red **UNK** in response to each keyboard press of the "Enter" button. This indicates that communications between the MDT and the computer have been established. Type in the following commands listed below, pressing "Enter" after each line.

**NOTE:** After each "ENTER", a yellow response should come back with the "A" after each command. This lets you know that the MDT acknowledged the change.

```
SQP + "ENTER"  
LKI 1 50 "ENTER"  
RKI 1 10 "ENTER"  
SRT 7 1000 0 0 0 0 "ENTER"
```

The **SQP** command sets the squelch polarity. This must be set to (+) for correct operation with the **ESP604**. If it is not, you will have a constant busy light on the MDT even when no RX signal is present.

The **RKI** and **LKI** command sets the repeater/transmitter key-up time in 10ms increments. A range of 50-150 for LKI is recommended to allow adequate time for data to pass through a trunking system.

The **SRT** command specifies the radio type and specific parameters for data transmission.

You can now exit the **EXC** program by clicking on the **CLOSE** box of the **DOS** window. Once these commands are entered and the correct acknowledgement has been received, the MDTs will be ready for installation.

## APPENDIX B

### King Mobile Data Terminal GPS Setup

Using the **King Communications CD** that was provided to do the Handyman Setup there should also be a directory on the CD called AVL. Open this directory and install the following programs.

1. **SetupAVL.EXE**
2. **Trantrac.EXE (This should include a map of your state you are operating in. May be under a different name specified by King Communications)**
3. If using Windows 95 then install **Dcom95.EXE** (Not needed for NT 4.0 or Win 98)

Using the procedure in **Appendix A**, connect up the terminal used for the mobile unit to the computer to run EXC. Run the **EXC** program and verify that you get the red **UNK** response back from the terminal. Enter in the following commands:

- A. **SER 4800 H N 10** - this sets the MDT communications to 4800 baud from the previous 19200 baud. After this command is given you must close the **EXC** program.
- B. Reset power on the MDT and open the EXC 4800 baud program. Verify that you get the red **UNK** response. Now enter : **SDA 20** This will activate the serial port on the MDT for 4800 baud which is required for a serial GPS unit. Close the **EXC** program.

### **MOBILE SETUP**

For the mobile setup - disconnect the serial port between the computer and the MDT which had the changes above made to it. Connect a serial GPS module such as the Garmin 35-HVS. Make sure power is applied to the GPS unit. Refer to the GPS manual for wiring instructions.

### **BASE SETUP**

For the BASE setup - Connect the **MDT** with ID 2024 back to the computer via the serial port. Launch the following programs in order:

1. **Winhost 1 or Winhost 2**
2. **AVLdriver.exe**
3. **Trantrac.exe or Equivalent mapping software.**

The mobile should now be sending updates to the base unit. Specific details in setting up the GPS data to match your map and the amount of updates may be found under the **EXC** documentation provided with the King Communications CD.