

INTERFACING LOCSYS, Inc. ROVER II & DATA MANAGER TO ESP604 DATA RADIO



This application note provides the basic cable wiring information for connecting a SEA ESP604 mobile data radio to the LOCSYS™ Rover II and LOCSYS Data Manager AVL tracking system. Additionally, a procedure is provided for minimally configuring the PC, base and mobile radio wiring so that the system can be tested using the WinAVL^{®} Version 1.x vehicle tracking software. The base unit named DATA MANAGER uses the dial-up networking feature of Microsoft Windows to connect to the PC as you would for an external modem. The information in this application note is believed to be correct at the time of issuance and is provided strictly as a courtesy to SEA customers without warranty.

1. Minimum system requirements:

- - 2 - SEA ESP604 Data Radios with AFSK data option board (ASY-0600-11) installed.
 - 2 - Radio to LOCSYS Rover II interface cables. Refer to section 2 for details.
 - 1 - LOCSYS Rover II with 1200 baud modem - programmed for use on SEA604 radios. See note below.
 - 1 - LOCSYS DATA MANAGER and serial cable for connection to PC comm port.
(Data Manager is the same as the Rover II without the GPS option.)
 - 1 - PC with 32-bit Windows 95 / 98 or NT 4.0 operating system.
 - 1 - Software: **WinAVL Version 1.x** with street map of operating area (By state).

- NOTE: Rover systems are pre-configured by LOCSYS internally for the radio system they are being used on. When ordering the AVL system from LOCSYS, specify that the system will be used with SEA ESP604 data radios.

2. Radio to Rover II wiring diagram:

-

NOTE: Base unit (DATA MANAGER) wiring is the same as the mobile for the DB-9 radio connection.

<u>PIN #</u>	<u>Description</u>	<u>PIN #</u>	<u>Description</u>
1	DCD	---	Not Used
2	RD	15	Modem audio-in (1200 Baud MSK)
3	TD	14	Modem audio-out (1200 Baud MSK)
4	CLK	---	Not Used
5	GND	17	Ground
6	DSR	9	Input - Digital / Analog (DSR)
7	PTT	11	Output - open collector to ground (PTT)
8	CTS	20	Input - Digital / Analog (0-12V) CTS
9	+13VSW	13	Input - Digital (0-12V) ignition

3. ESP604 Programming:

- Program the desired modes in the ESP604 to match the REPEATER SYSTEM(S) which will be used or CHANNEL(S) for talkaround use if no repeater is being used. Refer to the ESP604 programming manual for instructions on programming the radio for DATA operation.

A regular mode (not available on test modes) is programmed for 1200 bps data operation as follows:

Required Configuration Programming:

Data Option Type: MSK - (AFSK data option board must be installed)

Required Mode Programming:

Type: Trunked or Conventional
Area: Site Area bit
Home: Desired home channel of site
Busy Channel Y
Lockout:
Repeater Channel: Channel number in Home position
Data ID: RX and TX ID

When the radio is on a mode programmed for Voice & Data, the Local Mic may key for voice operation and the MDT may key for data operation. When the radio is on a mode programmed for Data Only, only the MDT may key it. Please note if selecting Voice & Data operation, a TX and an RX ID (that do not match the Data ID) are also required for the mode programming.

4. SEA Repeater system programming:

- Optional: Talkaround users may bypass this section.

Program the site repeater(s) according to the programming manual with the correct Channel Number, Area Bit and Home Channel. Test the repeaters with two mobiles in **VOICE** mode to insure the system is functioning properly before using **DATA** mode on the mobiles.

5. Mobile Station Configuration:

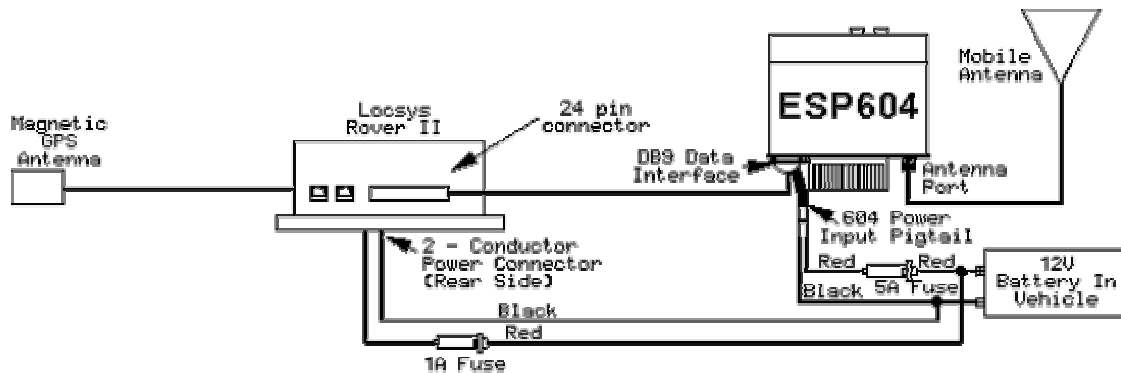

6. Base Station Configuration:

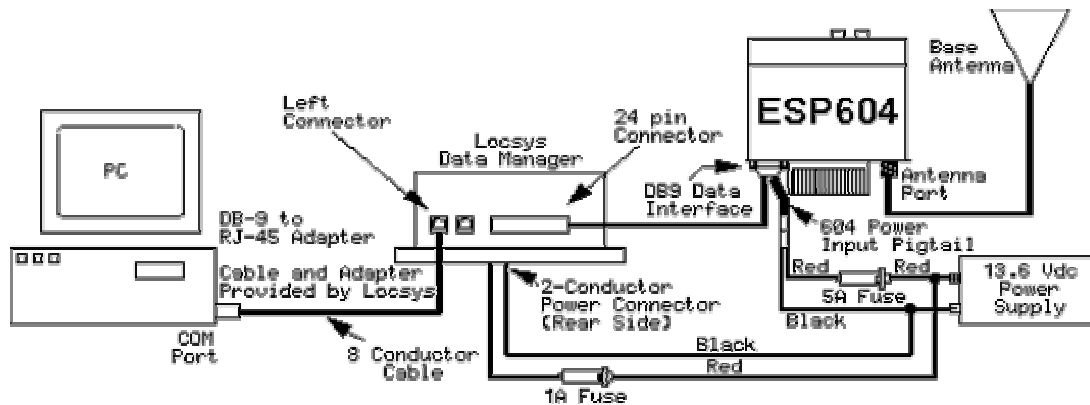

7. Minimum required Base Station Configuration Procedure:

- A. Load the **WinAVL Version 1.x** onto the computer by selecting "SETUP" on the CD ROM.
- B. Transfer the map(s) for the operating area into the **WinAVL** directory.
- C. Setup the **DIAL-UP Networking** configuration on the PC. Enter a 1 in the number to dial out since Microsoft programming will not allow this to be blank. Manually configure the modem as a **Standard modem at 9600 baud**.
- D. Activate the **DIAL-UP Networking** with the standard modem.
- E. Once the modem is connected, RUN the **WinAVL** program.
- F. If any errors occur during startup pertaining to missing files or the program will not execute, contact LOCSYS for help installing the software.
- G. See the instructions provided by LOCSYS for configuring the display and map properties.
- H. The system is now ready for single vehicle tracking. Additional mobiles may be added to the system but will require different software for operation. Contact LOCSYS for details on multiple radio configurations.

LOCSYS, INC.
A Location Systems Company
904 S. Park Ave.
Tucson, AZ 85719
PHONE: (520) 882-8730
FAX: (520) 624-2727
Website: www.locsys.com